

EVOLV EXPRESS™ SPECIFICATION SHEET

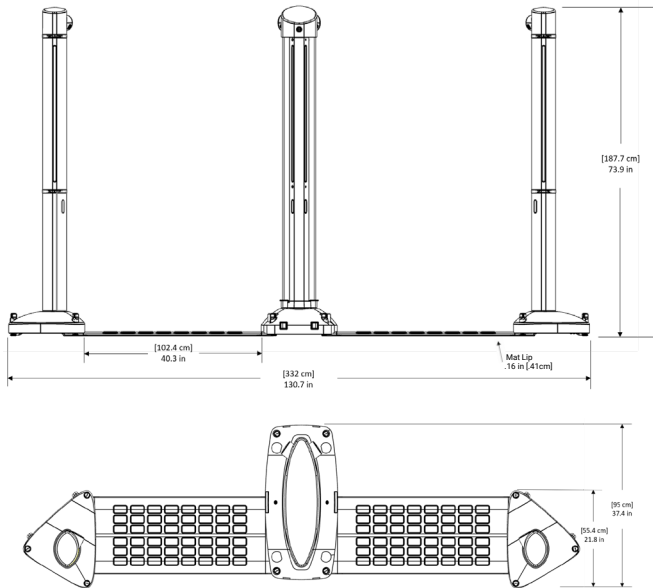
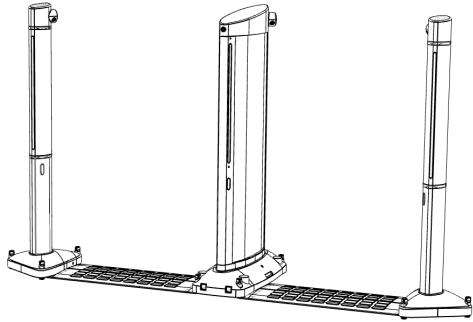

WHY EVOLV:

- Evolv Express™ is the world's first and only touchless security screening solution that meets all of the post-pandemic security screening requirements
- Only Express can **screen more than 3,600 people per hour**, eliminating the long lines of legacy weapons screening such as metal detectors, wands, and pat downs, making security human again
- With Express, **no stopping is required, no emptying pockets or removing bags** - people simply walk through this touchless security screening system
- Evolv has **screened more than 50M people**
- Evolv has **prevented more than 5,000 weapons** from entering venues
- Evolv's products are **in use worldwide** at corporate offices, schools, airports, sports stadiums and arenas, entertainment and hospitality venues, government facilities, hospitals, security forces, critical infrastructure and places of worship

ENVIRONMENTAL SPECIFICATIONS

Operating Temperature:	Min: -20C, Max: +55C
Storage Temperature:	Min: -40C, Max: +70C
Relative Humidity:	Up to 95%*
Ingress Rating:	Standard IP54 Outdoor IP56**

*Outdoor rated unit is Condensing

**Power and data connectors are IP67, resisting water ingress up to 6"

PHYSICAL SPECIFICATIONS

Dimensions:	Depth:	37.4in (95cm)
	Width:	130.7in (332cm)
	Height:	73.9in (187.7cm)
	Weight:	200lbs. (91kg)
	Mat Lip:	.16in (0.41cm)
Opening:	Width:	2 lanes, each 40.3in (102.4cm)
Power:	Voltage:	115VAC - 230VAC (+/-10%)
	Phase:	Single Phase
	Typical:	200W max power consumption
Input/Output:		Line Cord
		USB 2.0 (service access only)
		Ethernet (RJ45) for Tablet

USER INTERFACE

Tablet Display (15.6in / 39.6cm)

CONFIGURABLE SETTINGS

Multiple Performance Modes

Multiple Operating Modes

HEALTH AND SAFETY

FCC CFR Part 15, CE Mark (CE Directives and Standards)

Global CB Scheme per CBTL Safety Standard

UL 61010, EN 61010 and IEC 61010

U.S. Americans with Disabilities Act Compliant Access

INCLUDED WITH STANDARD SYSTEM

15.6inch Tablet 1 (39.6cm) Display on Floor Stand (2 per lane)
Standard or Outdoor tablets based on optional Outdoor unit

OPTIONAL ACCESSORIES & ADD-ONS

Up to 2 Additional Tablets with Floor or Desktop Stand

Thermal Imaging Package

Custom Panel Graphics

Operational Test Kit